

State Health Reform Assistance Network

Charting the Road to Coverage

ISSUE BRIEF
March 2013

Navigators and In-Person Assistors: State Policy and Program Design Considerations

Prepared by **Shelly Ten Napel** and **Daniel Eckel**, State Health Reform Assistance Network

The Affordable Care Act (ACA) and related guidance have established Navigators and In-Person Assistors (IPAs) to help individuals enroll in Health Benefit Exchanges (Exchanges). Several states have begun to make policy and operational decisions about both Navigator and In-Person Assistor programs that could be informative to other states. This brief is designed to provide basic information about the Navigator and IPA programs, outline important policy issues, and share resources and ideas from leading states. It is part of a developing series of reports related to consumer assistance and reflects an effort to curate the growing number and depth of resources available to state policymakers on this topic.

What are Navigators and In-Person Assistors?

One of the primary goals of the ACA is to make the purchase of health insurance simpler and more transparent for consumers. For that reason, states are creating user-friendly web portals to help consumers select the health plan that is right for them and their families. At the same time, we know that many people will not be able to navigate these websites easily on their own and others will want in-person assistance while making this important and complex decision. Navigators will educate people about the new system, help them understand their health plan choices, and facilitate their selection of the plan that is right for them.

The ACA requires that a Navigator program do the following ([ACA § 1311\(i\)](#)):¹

- Conduct public education to raise awareness about the availability of qualified health plans (QHPs);
- Distribute fair and impartial information;
- Facilitate enrollment into QHPs;
- Provide referrals to the appropriate entity or agency for consumers with a grievance, question or complaint; and
- Provide information that is culturally and linguistically appropriate to meet the needs of the population being served by the Exchange.

ABOUT STATE NETWORK

State Health Reform Assistance Network, a program of the Robert Wood Johnson Foundation, provides in-depth technical support to states to maximize coverage gains as they implement key provisions of the Affordable Care Act. The program is managed by the Woodrow Wilson School of Public and International Affairs at Princeton University. For more information, visit www.statenetwork.org.

ABOUT THE ROBERT WOOD JOHNSON FOUNDATION

The Robert Wood Johnson Foundation focuses on the pressing health and health care issues facing our country. As the nation's largest philanthropy devoted exclusively to health and health care, the Foundation works with a diverse group of organizations and individuals to identify solutions and achieve comprehensive, measureable and timely change. For 40 years the Foundation has brought experience, commitment, and a rigorous, balanced approach to the problems that affect the health and health care of those it serves. When it comes to helping Americans lead healthier lives and get the care they need, the Foundation expects to make a difference in your lifetime. For more information, visit www.rwjf.org. Follow the Foundation on Twitter www.rwjf.org/twitter or Facebook www.rwjf.org/facebook.

For more information, please contact Shelly Ten Napel at shelly.tennapel@academyhealth.org or 202.292.6721.

¹ These are the Section 1311(i) Navigator Duties presented in bullet form by Melinda Dutton of Manatt at a State Network meeting. The full presentation can be found at: <http://www.statenetwork.org/wp-content/uploads/2012/10/State-Network-Consumer-Assistance-SGC-Navigator-and-In-Person-Assistors.pdf#page=3>.

Based on these requirements, Navigators will primarily be individuals in community-based organizations or with unique community ties, who will link consumers to the Exchange. They will be one of the central public faces of the Exchange, and therefore critical to its success and public perception of its value.

It is important to note that the Cooperative Agreement to Support Establishment of the Affordable Care Act's Health Insurance Exchanges (establishment grants)² cannot be used to fund the grants to Navigators³. As outlined further below, states will need to include the cost of their Navigator grants in the self-sustainability plan for their Exchange. This has created an operational challenge because, while revenue may not begin to flow to the Exchange until premiums start to be paid, the Navigator program should be in place on or before October 1, 2013 when the first open enrollment period begins. The federal Center for Consumer Information and Insurance Oversight (CCIIO) has partially addressed this challenge in the June 29, 2012 update of the establishment grant funding opportunity announcement (FOA)⁴ by allowing states to develop IPA programs with establishment grant funds.

What are In-Person Assistors? In-Person Assistors are similar to Navigators, except they can be funded with establishment grant funds. CCIIO has indicated that IPAs will be required to meet similar standards and perform similar functions as Navigators. The FOA also requires that IPA programs be distinct from Navigator programs in some way. States can comply with that requirement in several ways, but they may choose to make their IPA program (if they choose to have one) similar to their eventual Navigator program for the sake of administrative simplicity.⁵

What are Certified Application Counselors? CMS provided additional [guidance](#) in January 2013 that identifies another category of consumer assistance: certified application counselors (CAC). The CAC program acknowledges that there may be many individuals in the community who are not paid directly by the Exchange as official Navigators or IPAs, but who are still helping consumers enroll in coverage through the web portal. These individuals must meet similar training requirements, security standards, and conflict of interest rules as IPAs and Navigators.

How will Navigator and IPA programs work in states with Federally-Facilitated Exchanges (FFE)s? The ACA gives states the choice of setting up a State-Based Exchange (SBE) or allowing the federal government to establish an FFE. States with an FFE can elect to partner with the federal government by managing certain tasks related to Plan Management and/or Consumer Assistance (FFE states that choose to partner with the federal government are referred to as Partnership states).⁶ The Navigator program is one specific area of consumer assistance in which an FFE state can maintain some influence. On January 3, 2013, CCIIO released additional [guidance](#) to describe how Navigator and IPA programs will operate in Partnership states. The guidance envisions close coordination between the state and the FFE, and details what roles will be the responsibility of the federal government and the state. According to the guidance, the federal government will establish the Navigator program, select the grantees, and issue the awards. They will also develop conflict of interest, cultural and linguistic competency, and training standards. States will conduct day-to-day management of the program, including monitoring whether Navigators are complying with federal standards. States can also develop training standards that Navigators must meet in addition to the federal standards.

Partnership states can also develop IPA programs to supplement the Navigator program. Establishment grant funds can be used to support these IPA programs in 2013 and 2014.

States Must Consider How Navigators Will Interact with Other Programs and Entities

Exchanges will sit between two existing insurance markets—the Medicaid program and the private market—each of which have existing entities that serve Navigator-type functions. The Medicaid market has a range of enrollment and outreach workers (the types and functions of these workers vary from state to state) and the private market traditionally has been served by producers (i.e., agents and brokers). In some states producers have been active in both the individual and small group market, while in other states they have primarily focused on employers in the small group market (often focusing their outreach and business development on larger small groups that provide a larger return on investment). States should carefully consider how Navigator functions will interact and overlap with existing Medicaid workers and private market producers. In addition, states will want to consider how Navigators will interact with Exchange call centers, consumer assistance programs and other mechanisms for consumer complaints and appeals, and other community and social service entities.

² Establishment grants are the mechanism by which the federal government is funding the planning and initial implementation work of states that are setting up state-based exchanges or that are working in partnership with the federal government in the establishment of a Federally-Facilitated Exchange. The last date to apply for establishment grant funds is October 15, 2014. (<http://cciio.cms.gov/resources/fundingopportunities/index.html#peg>). States must develop a self-sustainability plan to fund ongoing operations of the exchange; most will use some type of fee or broad-based tax on carriers.

³ While establishment grants cannot be used to fund grants to Navigators, states can use federal funds for administrative costs related to implementation of the Navigator program and for training Navigators.

⁴ The June 29, 2012 FOA was updated on November 30, 2012. This report links to the updated document.

⁵ For more information on In-Person Assistors see, "In-Person Assistors May Look a Lot Like Navigators" by Tricia Brooks from the Georgetown University Health Policy Institute Center for Children and Families at <http://ccf.georgetown.edu/all/in-person-assistors-may-look-a-lot-like-navigators/>

⁶ For more information on Exchange functions of an FFE see "General Guidance on Federally-Facilitated Exchanges" by CCIIO at <http://cciio.cms.gov/resources/files/ffe-guidance-05-16-2012.pdf>

Navigators and Producers. One of the first policy questions that many states have already faced is how their Navigator program will intersect with their existing producer community. Will producers be Navigators? Will Navigators reduce the need for producers? How can states leverage the experience and relationships of producers to help make the Exchange a success? In addition to these policy questions, redefining the role of producers moving forward can cause political challenges, as producers are often a strong political presence in many states.

Producers have been regulated and licensed by states for many years. Typically, they are required to complete training, pass a licensing exam, and maintain continuing education credits. The National Association of Insurance Commissioners (NAIC) has developed model language that requires licensure for a person who would “sell, solicit or negotiate insurance.” State laws vary, but producers have used this language to argue that only licensed producers should be able to help individuals enroll in health insurance through Exchanges. Some states are addressing this issue by allowing Navigators to assist and educate consumers, but not to specifically recommend a particular plan or to tell a consumer which plan to buy.

In most *State Network* states, both Navigators and producers will exist in the market after 2014. In many states producers will not become Navigators because the ACA prohibits them from receiving compensation directly or indirectly from carriers, which is the traditional producer compensation model. Nevertheless, producers will have a role in helping consumers enroll in the Exchange, especially in the small group market. While the roles of Navigators and producers overlap somewhat, it is likely they will serve different populations with Navigators focused on the individual (and Medicaid) market and the previously uninsured and producers predominantly serving the small group market and those who have had coverage in the past.

Leading states are establishing programs to strengthen the relationship between producers and the Exchange and to utilize producers as a resource. Maryland has established a [Producer Advisory Council](#) that will provide input on Exchange policy. Oregon is establishing an [Agent Advisory Committee](#) to advise its Exchange on quality improvements that could be made to the enrollment process. Oregon is taking this a step further by establishing an [Agent Management Program](#). The Oregon Exchange (called [Cover Oregon](#)) will require certification of agents and training related to products available in both Medicaid and the Exchange. The goal of the program will be to:

- Utilize and expand on the existing distribution channel provided by agents;
- Reach all geographic areas of the state;
- Make the Exchange the most desirable place for agents to place business by providing agents with reliable online tools and exceptional service; and
- Giving them a stronger consumer-facing product that includes access to tax credits and expanded decision support tools.

Navigators and the Medicaid Program. An earlier brief from the *State Network* and the National Academy for State Health Policy (NASHP) titled “[Building on a Solid Foundation: Leveraging Current Program and Infrastructure in the Navigator Program](#)” laid out three current types of Navigator-like entities in Medicaid programs:

- *Outstationed eligibility workers*, a requirement of the Medicaid program, are staff at Federally Qualified Health Centers (FQHCs) and disproportionate share hospitals (DSH) who are capable of handling initial receipt and processing of applications from pregnant women, children, and youth. ([42 USC 1396a\(a\)\(55\)](#); [42 CFR § 435.904](#))
- *Application assisters* are similar to outstationed eligibility workers but can do a larger range of tasks and can be based in either community groups or with providers.
- *Enrollment brokers* facilitate unbiased and informed enrollment into a Medicaid and/or CHIP managed care organization and help states meet the federal requirement that enrollment and disenrollment in Medicaid managed care is fair.

A Navigator program can build on the strengths of these existing programs by implementing lessons learned, recruiting the community organizations and staff that already contract with Medicaid to be Navigators, or ensuring strong coordination and cross-training between the Navigators and Medicaid workers.⁷

Navigators and Call Centers. Many consumers will use both Navigators and the Exchange call center. As such, the state will need to establish protocols for how the two will work together. In particular, the call center will need to refer consumers to Navigators if the caller prefers in-person assistance and states should consider whether these will be warm hand-offs (which could include a personal introduction or an exchange of information so the consumer is not required to repeat information) or simple referrals. Through the *State Network*, Wakely Consulting Group has prepared a [brief](#) on effective strategies for call center development.

Navigators and Appeals. Once consumers are enrolled in health coverage, some will encounter problems with billing and claims. Because the consumer has already worked with a Navigator, the state may decide that Navigators should help consumers file appeals and grievances with

⁷ The [January 13, 2013 notice of proposed rule-making](#) acknowledges the need for coordination and cross-training in their discussion of certified application counselors.

insurance plans. At a minimum, federal law requires that Navigators have the ability to refer consumers to an entity that can assist with grievances, questions, and complaints ([ACA § 1311\(i\)](#)). About half of states currently have a federally-funded Consumer Assistance Program (CAP)⁸ which provides consumers with information about health insurance and helps them file complaints and appeals with their insurance plans.

Most states also encourage consumers to file complaints with their state insurance department. It is critical that the insurance department receive these complaints because they use them to monitor market conduct by insurance carriers. If Navigators do help consumers with complaints, the state should consider how relevant issues are passed on to the insurance department so it can investigate carrier conduct in the market. If Navigators do not help consumers with complaints and appeals, then a referral protocol must be developed.

State Options for Funding a Navigator Program

As stated above, the grants and payments made to Navigators cannot be funded through establishment grants; however states can use federal funds for administrative costs related to implementation of the Navigator program and for training Navigators.⁹ As such, most SBEs and Partnership FFEs will fund the bulk of their Navigator programs through their selected Exchange funding mechanism, typically some sort of assessment on insurers. To the extent that Navigators also perform functions for the Medicaid program, states can seek federal matching funds at the state's administrative federal financial participation rate ([45 CFR § 155.210\(f\)](#)). If the Exchange and the state Medicaid program both utilize the services of the Navigators, they will need to develop a shared oversight plan that addresses—among other things—how costs will be allocated between the two programs.

Navigator Payments and Performance Metrics

States are primarily using grants to community groups as the payment mechanism for Navigators. As states establish their Navigator programs and issue their requests for proposals (RFPs), they have several issues to consider.

Payment Approach. States can adopt a block grant approach, a per-application approach, or they can develop criteria for incentive-based payments. They can also use a combination of the block grant approach (to help fund up-front and administrative costs) with an incentive or per-application method. Because Navigators will likely play a large role in assisting hard-to-reach populations, that should be a consideration as states develop their payment methodology.

The state's payment approach should be driven in part by the enrollment goals of the Exchange and the vision for the Navigator or IPA program. Some states may choose to emphasize outreach and education as a primary goal of Navigators, or they may focus on enrollment goals. States may also want to target specific hard-to-reach populations, or they may decide to focus on overall enrollment objectives. The goals of the program should inform the chosen payment approach. Because the IPA program will only exist in the first years of ACA implementation, a state may want to more heavily emphasize outreach and education in this program.

The role of Navigators in the small group market is likely to be quite different from the role of Navigators in the individual market. Small businesses will have unique needs and questions that are not relevant in the individual market. The Exchange should plan to have staff or Navigators who are highly trained to serve the small group market.

Most states have Medicaid application assistors and outstationed workers who are already active in the community, and states will need to consider how Navigator payments intersect with the payments to those groups. States will want to consider: Will Medicaid funding preclude Navigator funding? Will the states target the same groups for both types of funding? Will the role and training of Medicaid workers be expanded to include Exchange-related information?

Size and Scope of the Navigator Program. There are many considerations for states as they contemplate the size and scope of their Navigator program:

- States should consider how heavily they plan to rely on Navigators. Some states may decide that producers will continue to play a primary role in enrolling small businesses and their employees, which would reduce the need for a significant number of Navigators to work with small business. There may also be other state programs that would overlap with Navigators and reduce the need for Navigators in some geographic areas or with some targeted populations.
- States will likely want a larger initial team of Navigators or IPAs for the first one or two open enrollment periods. In-person Assistor funds could be used to support a higher early investment in outreach and in-person support for consumers. A larger workforce could raise initial awareness of the program and help consumers become familiar and comfortable with the website.

⁸ The Consumer Assistance Program (CAP) is described in detail at <http://www.healthcare.gov/law/features/rights/consumer-assistance-program/index.html>. Contact information for each state-based CAP program is provided here: <http://www.healthcare.gov/using-insurance/managing/consumer-help/index.html>

⁹ There has been no guidance or regulations on this matter but numerous establishment grant awards include Navigator planning, such as Arkansas: <http://ccio.cms.gov/archive/grants/states-exchanges/ar.html>. For more state examples please refer to: <http://ccio.cms.gov/Archive/Grants/exchanges-map.html>

- States should consider their own population, with particular emphasis on hard-to-reach populations. Low literacy levels, lack of access to broadband or other computer resources, and limited English proficiency will all limit the ability of consumers to independently enroll through the Exchange website and will increase the need for Navigator services.
- Use of in-person versus web-based services is likely to vary by region. States that have survey or other data to indicate which method of enrollment their target populations are likely to use can also take that information into consideration when deciding on the size of the program.

Once states have given consideration to the general scale of their Navigator program, there are some guidelines that could help them determine a final budget. In their work with states, Wakely Consulting Group has been estimating a cost of about \$50 - \$100 per completed application based on existing fees in several similar programs (listed below).¹⁰ It is important to note that Navigators and IPAs are likely to have a larger scope than other comparable programs, including education and outreach. The \$50 - \$100 range may be more appropriate for ongoing operations once a Navigator program is established, with additional resources allocated in the early years as the program is established, staff is trained, infrastructure is developed, and the enormous task of educating the public in the early years of ACA implementation is complete.

State	Program	Compensation*
Federal	Pre-Existing Condition Insurance (PCIP) brokers	\$100
Maryland	MHIP (High Risk Pool) Broker	\$100
Illinois	All Kids Application Agents	\$50
California	Enrollment Entities and Certified Application Assistants	\$60
Oregon	Healthy Kids Application Assistants	\$75

*Per successful application

Program Management and Coordination. States may want to consider the possibility of contracting for program oversight and monitoring. If Navigators are ultimately placed in a large variety of organizations (in order to reach a diverse population), states may want a community-based group that is charged with program oversight and management. Management functions could include coordination of a regional strategy (as Maryland has proposed, see below), development of quality and evaluation standards for individual Navigators, and/or being responsible for compliance and reporting back to the Exchange. A program coordinator could also ensure that connections and hand-off protocols are being developed between Navigators and other local and state groups (in both the public and private sector).

Conflict of Interest

Federal regulations state that Navigators cannot work for a health insurer, a subsidiary of a health insurer, an association of members that includes or lobbies on behalf of insurers, and they cannot receive any compensation directly or indirectly from an insurer ([45 CFR § 155.210\(d\)](#)). In addition, states must develop conflict of interest standards that may address issues such as:

- Financial and nonfinancial considerations;
- Family member's employment activities;
- Monitoring of Navigator-based enrollment patterns;
- Legal and financial resources for consumers who have been adversely affected by a Navigator with a conflict of interest; and,
- Applicable civil and criminal penalties for Navigators who act in a manner inconsistent with the conflict of interest standards set forth by the Exchange. (Dutton, 2012)

Performance Metrics and Program Evaluation

Performance metrics can be used in the Navigator payment strategy or to evaluate the performance of Navigators. The following is a list of potential performance metrics based on information from *State Network* states:

- Number of applicants enrolled;
- The rate of completed enrollments relative to applicants assisted;

¹⁰ Note that the range per application should be considered a benchmark for estimating a total budget. Most states will not rely exclusively on a per-application payment model.

- Number of referrals (or enrollments) made to Medicaid;
- Number of referrals to social services programs such as the Supplemental Nutrition Assistance Program (SNAP, formerly referred to as food stamps) or the Women, Infants and Children (WIC) program;
- Number of applicants in various target populations (those with language barriers or who have been uninsured for a longer time) assisted and enrolled;
- High scores on customer satisfaction surveys;
- High use of the web portal;
- Rates of continuous coverage (efforts to prevent coverage disruptions due to a change in program eligibility);
- Enrollment patterns (to ensure consumers are not being overly steered to one plan or another); and,
- Accuracy of the applications submitted.

Many of the metrics listed above can be monitored through the web portal or through reporting from the Navigators. States also may wish to conduct independent analysis of their Navigators. Some possible evaluation strategies are customer service surveys; focus groups with grantees, volunteers, community groups and eligibility workers to assess the program and identify ways to improve it; and, independent monitoring of outreach activities and marketing materials produced by Navigator entities.

Navigator Training

Federal regulations ([45 CFR § 155.210\(b\)\(2\)](#)) stipulate that states must establish a set of training standards for Navigators to ensure their expertise in:

- Understanding the needs of underserved and vulnerable populations;
- Eligibility and enrollment rules and procedures;
- The range of QHP options and insurance affordability programs; and,
- Privacy and security standards.

HHS has indicated they will issue model training standards in forthcoming guidance to help Navigator applicants demonstrate they can carry out minimum Navigator duties. ([77 Federal Register 59, pp. 18331](#))

Nearly every Navigator policy decision impacts training—as decisions are made about issues such as conflict of interest standards and performance metrics, those decisions must be incorporated into the training program. As an example, the following is the list of training modules recommended by the Navigators, Agents and Brokers Workgroup of the Minnesota Health Insurance Exchange:

- Affordable Care Act
- Minnesota Health Insurance Exchange 101
- Needs of underserved and vulnerable populations
- Qualified Health Plans and Insurance Affordability Programs
- Eligibility and enrollment rules and procedures
- Means of appeal and dispute resolution
- Conflict of interest
- Exchange privacy and security policies and requirements/standards
- Consumer assistance support
- Coverage renewal
- Proficiency/competency assessment or “minimum standards” / continuing education / re-certification
- Outreach and education

- Small Business Health Options Program (SHOP)
- Licensure requirements

States will need to determine the duration of their Navigator training and which modules can be taken online versus which training will be in-person. States must determine whether any non-Navigator entities will be required to complete components of the Navigator training or if Navigators will be required to participate in trainings offered to other groups (such as Medicaid enrollment workers or brokers). Although states cannot use establishment grants to fund their Navigator program, they may use them to develop and coordinate their Navigator training.

Conclusion

The goal of the ACA is to expand access to quality health coverage, and Navigators and IPAs will be critical to the success of that mission. These programs will be working in a challenging environment that is characterized by: a low level of knowledge about the new coverage options available; skepticism that help is available; and, a lack of familiarity with insurance rules and terms. In spite of all the technical issues that must be resolved, Navigator and IPA programs will be successful if program developers keep focused on the needs of consumers and the goal of increasing coverage.

Acknowledgement: The authors wish to thank the many people who reviewed and provided insights that contributed to this brief. In particular, we relied heavily on the work of Melinda Dutton at Manatt Health Solutions. We also received valuable input from Kathie Mazza at the Wakely Consulting Group and the entire *State Network* management team. We also wish to acknowledge the excellent work of the staff of the Maryland Health Connection (especially Leslie Lyles Smith, Director of Operations) who has provided an early roadmap for Navigator and IPA policy making.

State Example - Maryland

The Maryland Navigator and In-Person Assistor Program

On January 17, the Maryland Health Benefit Exchange issued a [grant solicitation](#) for their Navigator and IPA program. This followed the passage of the [Maryland Health Benefit Exchange Act of 2012](#), and a [request for information](#) for input into the Navigator program, particularly from [interested navigator organizations](#). Prior to development of the grant solicitation, Maryland commissioned a [study](#) of consumer assistance and developed [policy options and a projected timeline](#) for the Navigator Advisory Committee.

Maryland's Approach to Contracting with Navigators and In-Person Assisters

Maryland has taken a regional approach to the coordination of their Navigator and IPA program. Its grant solicitation divides the state into [six regions](#) and asks organizations to apply to be the Connector Entity for the region. That Connector Entity will be responsible for coordinating Navigator and IPA services throughout the region and are encouraged to partner with other organizations to ensure that all target populations are well-served.

Maryland's Connector Entities

The Maryland proposed structure for their Navigator/IPA program is as follows:

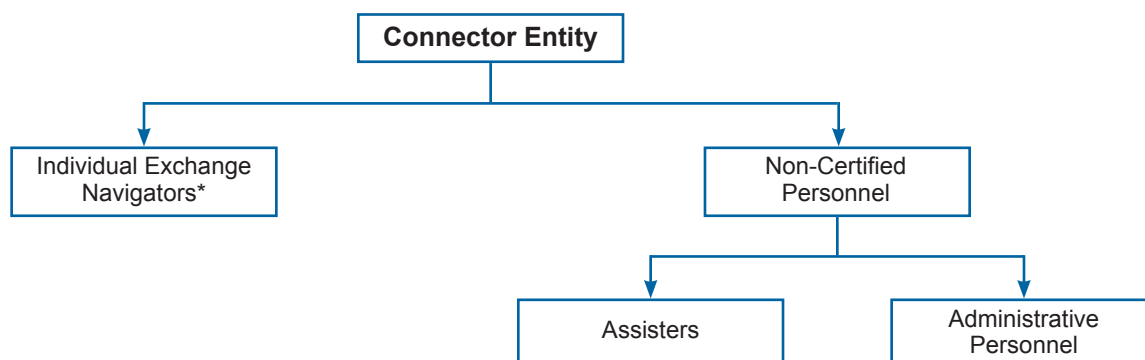

*Option of also becoming SHOP Exchange Navigators

The Connector Entity will coordinate all services for the region and will be responsible to the state for all deliverables. The Connector Entity will contract with Individual and/or SHOP Exchange Navigators who will meet all the requirements under the law for Navigators and IPAs. They will be largely responsible for helping individuals enroll in coverage. Maryland also recognized that there are many tasks that could be accomplished by non-certified assistors and other personnel, including outreach, education, assistance with Medicaid eligibility and enrollment, facilitating referrals, and administrative services.

State Support Provided to the Connector Entities

The Maryland RFP outlines the supportive services that will be provided to assist individuals enrolling in the [Maryland Health Connection](#) (the Maryland Health Benefit Exchange) with whom the Connector Entities will be required to coordinate, including:

- The Maryland Health Connection website (including minimum web capability requirements);
- The Maryland Health Connection call center (the solicitation includes expectations related to referrals and hand-offs);
- Outreach and educational material (which will include approved language and messaging but will allow Connector Entities to adapt based on their needs);
- Initial and annual training program; and
- Tools and services to assist hard-to-reach populations, including:
 - Access to a 24/7 language line for translation services (Connector Entities are responsible to have staff available for Spanish and other languages that represent three percent or more of the population of the region);
 - Sign language interpreters;

- TTY/TTD capability for the hearing impaired; and
- Translation services for educational materials, including to Braille.

The Connector Entities will be asked to propose how they will facilitate appropriate hand-offs to the supportive services listed above and to Maryland Medicaid and human services programs. The guidance outlines specific protocols for hand-offs with the Maryland Insurance Administration.

Training

Maryland plans to provide additional training requirements in future guidance, but the current guidance states that Individual and SHOP Exchange Navigators will be required to complete 120 hours of in-person training and successfully complete a final exam. Training is broken down to three 40-hour weeks each on: Policies and Procedures; Medicaid and MCHP; and the Maryland Health Connection.¹¹

Performance Metrics

The Maryland Health Connection will establish performance metrics in order to track the following: 1) the overall impact of connector entities on enrollment into insurance products; 2) performance as it relates to specific vulnerable and/or hard-to-reach populations; 3) whether or not steering is occurring; 4) consumer satisfaction; and 5) level of effort required to enroll an individual in a health insurance product.

Budget

The first grant period will be from July 1, 2013 through June 30, 2014. The total program funding for Year One is \$24.8 million in two funding streams: approximately \$8.6 million in funds to support Navigator staff costs and \$16 million in federal grant funds to support program start-up, assistants, and other functions in the first year of operations. Connector Entities will be required to separately track and report Navigator staff costs and other functions being funded with federal resources. Funding may decline in later years due to loss of federal funds. A portion of the federal funds will be used to form a Performance Incentive Program (described below). In order to enable other states to compare the scope of Maryland's program to their own, The Hilltop Institute [projects](#) 147,233 people will enroll in the Maryland Health Connection in 2014 (the total number of uninsured U.S. citizens in Maryland is 546,422).

	Total Navigator and IPA	Navigator funds only
Total Navigator/IPA spending in Maryland	\$24.8 million	\$8.6 million
Total Navigator/IPA spending per projected Maryland Health Connection enrollee in 2014	\$168.44	\$59.77
Total Navigator/IPA spending per uninsured U.S. citizen in Maryland	\$45.38	\$16.10

Maryland is establishing a Performance Incentive Program based on new enrollment in a Connector Entity's region in both Medicaid and the Maryland Health Connection. The enrollment baseline is set at the state estimate (from The Hilltop Institute) for enrollment. Connector Entities can earn Level 1, 2, or 3 bonuses over their federal funding pool if they exceed the baseline by 10, 20, or 30 percent. Enrollment levels will be tracked independently and Connector Entities will be rewarded based on total enrollment in their region.

¹¹ An overview of the initial and annual training program for Navigators can be found on page 9 of the MHBE Grant Solicitation for Regional Connector Entities: http://marylandhbe.com/wp-content/uploads/2013/01/Connector_Entity_-Grant_-Solicitation1.pdf#page=9

Federal Regulations

- Certified Application Counselors, 78 Federal Register 14 (2013, January 22), pp. 4605 <http://www.gpo.gov/fdsys/pkg/FR-2013-01-22/pdf/2013-00659.pdf#page=13>
- Establishment of outstation locations to process applications for certain low-income eligibility groups, 42 CFR § 435.904 (2002, October 1). <http://www.gpo.gov/fdsys/pkg/CFR-2002-title42-vol3/pdf/CFR-2002-title42-vol3-sec435-904.pdf>
- State plans for medical assistance, 42 USC 1396a(a)(55) <http://www.gpo.gov/fdsys/pkg/USCODE-2010-title42/pdf/USCODE-2010-title42-chap7-subchapXIX-sec1396a.pdf>
- Navigator Program Standards, 45 CFR § 155.210(b)(2) (2012, March 27) <http://www.ecfr.gov/cgi-bin/retrieveECFR?gp=1&SID=960f9227e6c628462549f55e50ea344c&ty=HTML&h=L&r=PART&n=45y1.0.1.2.71#45:1.0.1.2.71.3.27.3>
- Navigator Program Standards, 45 CFR § 155.210(d) (2012, March 27) <http://www.ecfr.gov/cgi-bin/retrieveECFR?gp=1&SID=e84fd25753b57d6294f2cf6882ff7e06&ty=HTML&h=L&r=PART&n=45y1.0.1.2.71#45:1.0.1.2.71.3.27.3>
- Navigator Program Standards, 45 CFR § 155.210(f) (2012, March 27) <http://www.ecfr.gov/cgi-bin/retrieveECFR?gp=1&SID=e84fd25753b57d6294f2cf6882ff7e06&ty=HTML&h=L&r=PART&n=45y1.0.1.2.71#45:1.0.1.2.71.3.27.3>
- Navigator Program Standards, 77 Federal Register 59 (2012, March 27), pp. 18331 <http://www.gpo.gov/fdsys/pkg/FR-2012-03-27/pdf/2012-6125.pdf#page=23>
- Affordable Choices of Health Benefit Plans – Navigators, Patient Protection and Affordable Care Act, Public Law 11-148 § 1311(i) <http://www.gpo.gov/fdsys/pkg/BILLS-111hr3590enr/pdf/BILLS-111hr3590enr.pdf#page=62>

Resource List

- Brooks, T. (2012, November 5). *In-Person Assistors May Look a Lot like Navigators*. Retrieved January 3, 2013 from <http://ccf.georgetown.edu/all/in-person-assistors-may-look-a-lot-like-navigators/>
- Center for Consumer Information and Insurance Oversight (n.d.) *Creating a New Competitive Marketplace: Affordable Insurance Exchanges*. Retrieved January 15, 2013 from <http://cciio.cms.gov/Archive/Grants/Exchanges-map.html>
- Center for Consumer Information and Insurance Oversight (n.d.) *Exchange Establishment Cooperative Agreement Funding FAQs*. Retrieved January 24, 2013 from <http://cciio.cms.gov/resources/factsheets/hie-est-grant-faq-06292012.html>
- Center for Consumer Information and Insurance Oversight. (2012, May 16). *General Guidance on Federally-facilitated Exchanges*. Centers for Medicare & Medicaid Services: <http://cciio.cms.gov/resources/files/ffe-guidance-05-16-2012.pdf>
- Center for Consumer Information and Insurance Oversight. (2012, November 30). *Cooperative Agreement to Support Establishment of the Affordable Care Act's Health Insurance Exchanges*. Centers for Medicare & Medicaid Services: <https://www.grantsolutions.gov/gsl/preaward/previewPublicAnnouncement.do?id=15353>
- Center for Consumer Information and Insurance Oversight. (2013, January 3). *Guidance on State Partnership Exchange*. Centers for Medicare & Medicaid Services: <http://cciio.cms.gov/resources/files/partnership-guidance-01-03-2013.pdf>
- Dolan, R., Miller, C., Mooney, K. & Gauthier, A. (2012, August). *Building on a Solid Foundation: Leveraging Current Programs and Infrastructure in Navigator Program Development*. Princeton, NJ: State Health Reform Assistance Network. <http://www.statenetwork.org/wp-content/uploads/2012/07/State-Network-NASHP-Leveraging-Current-Programs-in-Navigator-Development.pdf>
- Dutton, M. (2012, October). *Navigators and In-Person Assistors: Exchanges*. State Health Reform Assistance Network: Consumer Assistance Small Group Convening. <http://www.statenetwork.org/wp-content/uploads/2012/10/State-Network-Consumer-Assistance-SGC-Navigator-and-In-Person-Assistors.pdf>
- Dutton, M. (2012, October). *Navigators and In-Person Assistors: Medicaid Integration*. State Health Reform Assistance Network: Consumer Assistance Small Group Convening. <http://www.statenetwork.org/wp-content/uploads/2012/10/State-Network-Consumer-Assistance-SGC-Navigators-and-In-Person-Assistors-Medicaid-Integration.pdf>
- Healthcare.gov. (2012, August 24). *Consumer Assistance Program*. Retrieved January 9, 2013 from <http://www.healthcare.gov/law/features/rights/consumer-assistance-program/index.html>

- Wakely Consulting Group. (2012, October 4). *Navigators and In-person Assistors: Exchanges*. State Health Reform Assistance Network: Consumer Assistance Small Group Convening. <http://www.statenetwork.org/wp-content/uploads/2012/10/State-Network-Consumer-Assistance-SGC-Navigators-In-Person-Assistors.pdf>
- Wakely Consulting Group. (2012, October 4). *Navigators and In-person Assistors: Medicaid Integration*. State Health Reform Assistance Network: Consumer Assistance Small Group Convening. <http://www.statenetwork.org/wp-content/uploads/2012/10/State-Network-Consumer-Assistance-SGC-Navigators-In-Person-Assistors-Medicaid-Integration.pdf>
- Wakely Consulting Group. (2013, February). *What Should Exchanges Know about Call Centers: A Guide for Implementation*. Princeton, NJ: State Health Reform Assistance Network. <http://www.statenetwork.org/resource/what-should-exchanges-know-about-call-centers-a-guide-for-implementation>

State Materials

- Dutton, M., Woda, S., & Smith, M. (2011, November 6). *Study of Navigator Program and Consumer Assistance*. Maryland Health Benefit Exchange: <http://dhmh.maryland.gov/Exchange/pdf/FinalNavigatorReportManatt.pdf>
- Dutton, M., Woda, S., & Smith, M. (2012, November 15). *Options for Design and Implementation of Maryland's Navigator Program*. Maryland Health Benefit Exchange: <http://dhmh.maryland.gov/exchange/pdf/MHBE%20Navigator%20Report%20Final.pdf>
- Manatt Health Solutions. (2012, October 23). *Project on Navigator Training, Procurement and Role Definition*. Maryland Health Benefit Exchange Navigator Advisory Committee: <http://dhmh.maryland.gov/Exchange/pdf/MHBE%20Navigator%20Adv%20Committee%20Oct%2023rd%20FINAL.pdf>
- Maryland Health Benefit Exchange. (2012, August 3). *Request for Information: Navigator Program*. <http://dhmh.maryland.gov/exchange/pdf/MD%20HBE%20Navigator%20Program%20RFI.pdf>
- Maryland Health Benefit Exchange (2013, January 16). *Connector Entity – Notice of Intent Responses*. <http://marylandhbe.com/wp-content/uploads/2013/01/Notice-of-Intent-Responses-Jan162013.pdf>
- Maryland Health Benefit Exchange Connector Program. (2013, January). *Grant Solicitation – Regional Connector Entities*. http://marylandhbe.com/wp-content/uploads/2013/01/Connector_Entity_Grant_-Solicitation-REVISED.pdf
- Maryland Health Benefit Exchange Act of 2012, Md. HB 443 (2012, March 20). <http://mgaleg.maryland.gov/2012rs/bills/hb/hb0443t.pdf>
- Minnesota Health Insurance Exchange. (2012, October 24). *Navigator, Agent and Broker Work Group: Advisory Task Force Meeting*. <http://mn.gov/commerce/insurance/images/ExchATFnavReportServiceLevels10-24-12.pdf>
- Minnesota Health Insurance Exchange. (2012, November). *Exchange Blueprint Application Documentation: 2.6 Operating Navigator Program, 2.7 In-Person Assistance Program, 2.8 Role of Agents and Brokers*. <http://mn.gov/commerce/insurance/images/2%252E6%25202%252E7%25202%252E8%2520%2520Navigator%2520White%2520Paper.pdf>
- New York Health Benefit Exchange (2012, October 26). *Blueprint Submission for Sections 2.6 and 2.7: Navigators and In Person Assistance*. <http://healthbenefitExchange.ny.gov/sites/default/files/2.6%20%2B%202.7%20-%20Navigators%20and%20IPAs.pdf>
- Oregon Health Insurance Exchange Corporation. (2012, February). *Agent Management Program*. <http://www.pahuonline.org/wp-content/uploads/2012/04/Agent-Mgmt-Program-draft.pdf>
- The Hilltop Institute. (2012, July 12). *The Economic Impact of ACA*. Maryland Health Benefit Exchange. <http://marylandhbe.com/wp-content/uploads/2012/10/Model-Projections-July-12.pdf>